

# **INTRODUCTION TO SURVEILLANCE CAMERA CONTROL SYSTEM**

## **Introduction**

Definition of an embedded system is various type of computer system or computing device that performs a dedicated function and/or is designed for the use with a specific embedded software application. Embedded systems may use a combination of read-only as well as with read-write based operating system. But an embedded system is not usable as a commercially viable substitute for general- purpose computers or devices.

Micro controllers are widely used in embedded system products. An embedded product uses a microcontroller to do one task only. In embedded system there is only one application software that is typically burned into ROM. Although microcontrollers are preferred choice for embedded system, there are times that microcontroller is inadequate for the task.

Video surveillance system is a surveillance system which uses a camera to detect the object and transmit the information to remote host, It addresses real time observation leading to a description of actions and interactions. The camera used in the surveillance system has different covering ranges. There are cameras which cover small ranges which are basically used for an indoor application such as in house, Factories, industries, banks and many restricted areas etc.

## **SYNOPSIS:**

Information appliances and computing are the wave of the future, yet many of us are designing and implementing software for desktop or server machines with hundreds of Mbytes of RAM running at hundreds of MHz, there by drawing hundreds of watts. To exploit the power of our machines, we run on them operating systems, programming languages, development tools, and communication protocols of great complexity.

Microcontroller projects with basic stamps introduces a different world, where program listing fit on single page, memory resources are measured in bytes, and self-contained designs communicate directly with the outside world using switches, lights, and motors.

## **PURPOSE:**

The main purpose of this project is to capture video by using surveillance camera control system in remote areas where security is needed. This technology is widely used for the banks, shops, historical places where it requires lot of security.

In this system the surveillance camera control system will be controlled through the intelligent Micro controller systems which in turn control various stepper motor. Previously the DC motor is used to control the surveillance camera but by using DC motor precision is not obtained. Therefore we use stepper motor to obtain 100% accuracy areas we need to cover a wider range.

## **BLOCK DIAGRAM OF TRANSMITTER AND RECIEVER**

### **DIAGRAM OF TRANSMITTER**

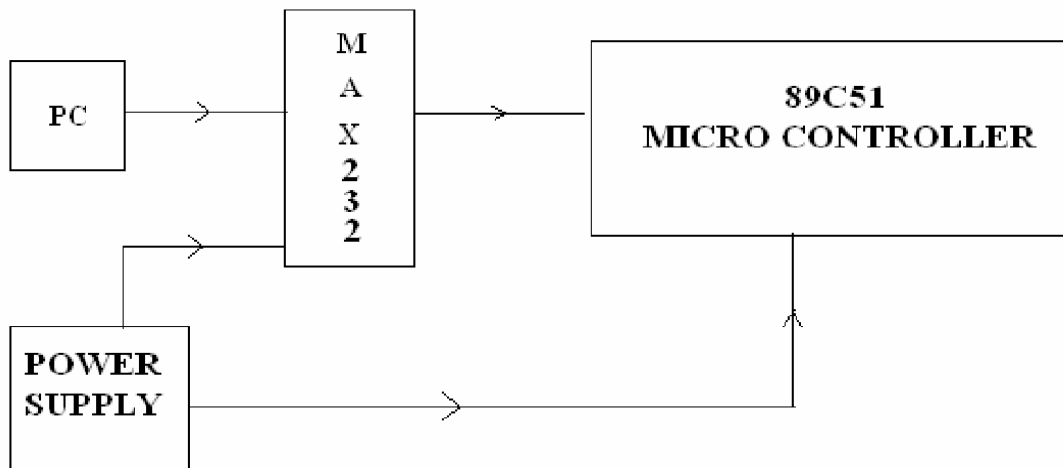

### **BLOCK DIAGRAM OF RECEIVER**

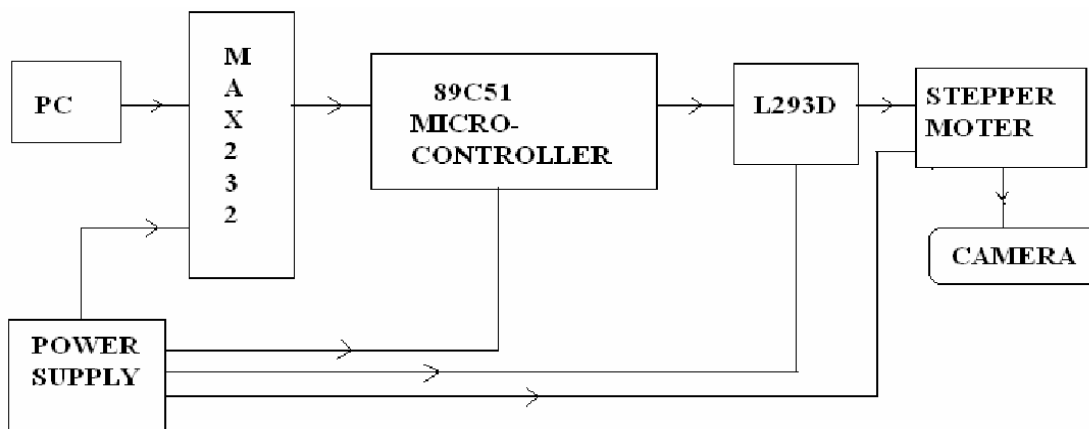

## **AT89C51 MICRO CONTROLLER**

### **DESCRIPTION**

The AT89C51 is a low power , higher-performance CMOS 8-bit microcomputer with 4kbytes of flash programmable and erasable read only memory (PEROM).The device is manufactured using Atmel's high density nonvolatile memory technology and is compatible with the industry-standard MCS-51 instruction set and pin out. The on-chip flash allows the program memory to be programmed in system or by a conventional non volatile memory programmer. By combining a versatile 8-bit CPU with flash on a monolithic chip, the Atmel AT89C51 is a powerful microcomputer which provides a highly- flexible and cost effective solution to many embedded control applications.

### **AT89C51**

The AT89C51 provides the following standard features: 4Kbytes of flash, 128 bytes of RAM, 32 I/O lines, two 16-bit timer/counters, a five vector two-level interrupt architecture, a full duplex serial

port, on chip oscillator and clock circuitry. In addition, the AT89C51 is designed with static logic for operation down to zero frequency and support to software selectable power saving modes. The idle mod stops the CPU while allowing the RAM, timer/counters, serial port and interrupt system to continue functioning the power-down mode saves the RAM connects but freezes the oscillator disabling all other chip functions until the next hardware reset.

## **MEMORY ORGANISATION OF 89C51 MICROCONTROLLER**

### **Program Memory:**

The 89C51 has separate address spaces for program and data memory. The program memory can be up to 64k bytes long. The lower 4k can reside on-chip. The 89C51 can address up to 64k bytes of data memory to chip the MOVX instruction is used to access the external data memory.

The 89C51 has 128 bytes of RAM, plus a number of special function registers (SFERS). The lower 128 bytes of RAM can be accessed either by the direct addressing (MOV data addr) or by indirect addressing ([MOV@RI](#)).

## **IC MAX 232 (SERIAL COMMUNICATION)**

### **FEATURES OF MAX232:**

Meets or exceeds TIA/EIA-232-F and ITU; Recommendation V.28; Operates from a single 5-V power supply; with 1.0-F charge-pump capacitors; Operates up to 120k bit/s; Two drivers and two receivers; 30-V input levels; Low supply current...8mA typical; ESD protection exceeds JESD22; 2000-V human-body model(A114-A); upgrade with improved ESD(15-kV HBM) and 0.1-<sub>F</sub> charge-pump capacitors.

### **APPLICATION OF MAX232**

Battery-powered system; terminals, modems, and computers portable computers, low power modems; interface translation; battery-powered RS-232 Systems; Multi drop RS-232 Systems; auto shutdown and UCSP are trademarks of maxim integrated products, inc.; drivers/receivers; for low-voltage, integrated ESD applications.

### **DESCRIPTION OF MAX232:**

The MAX232 is a dual driver/ receiver that includes capacitive voltage generator to supply TIA/EIA-232-F voltage levels from a single 5-V supply. Each receiver converts TIA/EIA-232-F inputs to 5-V TTL/CMOS levels. These receivers have a typical threshold of 1.3V, a typical hysteresis of 0.5 V, and can accept  $\pm 30V$  inputs. Each driver converts TTL/CMOS input levels into TIA/EIA-232-F levels. The driver, receiver, and voltage-generator functions are available as cells in the Texas instruments LinASIC library.

## **STEPPER MOTTOR AND L293D**

A stepper motor is a kind of electric motor with an internal rotor containing permanent magnets and a set of electro-magnets around that which are switched electronically.

Stepper motors "cog" to a limited number of positions, but with a micro stepping controller, stepper motors can rotate more smoothly.

The primary advantages of stepper motors are that since they move only as the controller changes the coil that is energized, the position of the motor to be turned out of phase with the coil excitation, which is known as skipping or missing steps, in most cases the reduced cost of the system is justified. Stepper motors are "brushless" unlike most other motors and so generate less Eml. Disadvantages include lower power efficiency, higher cost per unit, and the need for a more complex drive circuit aka controller.

The stepper motor controller typically accepts two inputs from an external source; step and direction. The direction signal set the direction of rotation and each pulse on the step signal causes the controller to move the motor one step in that direction. The controller translates these signals into different patterns of current flow in the coil, which result in the moment of the motor.

A stepper motor can be operated in two modes

1. Half step
2. Full step

### **Driving stepper motor with the L293D:**

The L293D contains two H-bridges for driving small DC motors. It can also be used to drive stepper motors because stepper motors are, in fact, two (or more) coil being driven in a sequence, backwards and forwards and forwards. One L293D can, in theory, drive one bi-polar 2 phase stepper motor, if you supply the correct sequence. Both of the bipolar and unipolar stepper motors are 3.6 degrees/step motors. The stepper motor runs at about 5 volts and pulls 800 milli-amps of current.

## **REGULATED POWER SUPPLY**

### **DESCRIPTION**

A variable regulated power supply, also called a variable bench power supply, is one where you can continuously adjust the output voltage to your requirements. Varying the output of the power supply is the recommended way to test a project after having double checked parts placement against circuit drawings and the parts placement guide.

This type of regulation is ideal for having a simple variable bench power supply. Actually this is quite important because one of the first projects a hobbyist should undertake is the construction of a variable regulated power supply. While a dedicated supply is quite handy e.g. 5V or 12V, it's much handier to have a variable supply on hand, especially for testing.

Most digital logic circuits and processors need a 5 volt power supply. To use these parts we need to build a regulated 5 volt source. Usually you start with an unregulated power supply ranging from 9 volts to 24 volts DC (A12 volt power supply is included with the Beginner kit and the Microcontroller beginner kit.). To make a 5 volt power supply, we use a LM7805 voltage regulator IC (integrated circuit).

## **SURVEILLANCE CAMER USED FOR THE PROJECT**

### **FEATURES:**

- Multi function
- Small size and light weight
- Low power consumption
- Power supply easy to install

### **APPLICATIONS:**

- Widely used for monitoring
- Video meeting
- Video E-mail
- Video door bell
- Video phone
- Computer
- Car reverse

## **SPECIFICATION AND FUNCTION:**

<b>FUNCTION</b>	<b>B/W Series</b>	<b>Color series</b>
• Image resolution	350 lines	380 lines
• Minimum illumination	0.5 Lux	0.5 Lux
• Output system	CCIR/EIA(PAL/NTSC)	Visual signal
• Lens focus and angle	3.6mm 69 degree	6.0mm45 degree
• Auto shutter	1/60 seconds – 1/15.00sec	-
• Power supply	6-12V	6-12V
• consumption	90mW	120mW

## **KEIL SOFTWARE AND CODING**

### **INTRODUCTION:**

An assembler is a software tool designed to simplify the task of writing computer programs. It translates symbolic code into executable object code. This object code may then be programmed into a microcontroller and executed. Assembly language programs translate directly into CPU instructions which instruct the processor what operations to perform. Therefore, to effectively write assembly programs, you should be familiar with both the microcomputer architecture and the assembly language.

An assembly program has three constituent parts:

1. Machine instruction
2. Assembler directives
3. Assembler controls

A machine instruction is a machine code that can be executed by the machine. Detailed discussion of the machine instructions can be found in the hardware manuals of the 8051 or derivative microcontroller.

Assembler directives are used to define the program structure and symbols, and generate non-executable code (data, messages, etc.). Assembler directives instruct the assembler how to process subsequent assembly language instructions. Directives also provide a way for you to define program constants and reserve space for variables.

Assembler controls set the assembly modes and direct the assembly flow. Assembler controls direct the operation of the assembler when generating a listing file or object file. Typically, controls do not impact the code that is generated by the assembler. Controls can be specified on the command line or with in an assembler source file.

## **RESULT ANALYSIS**

### **Automated video security**

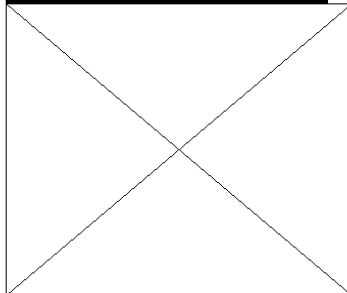

Infrared video analysis of deer crossing a road

Automatic driver alert could be posted on roadside message display.

Computer automated image analysis or video surveillance can automatically detect

Unusual events and trigger alarms, thereby reducing the volume of data presented to security personnel.

Computer automated video surveillance can monitor large areas and handle complex time-varying images. A video feed for surveillance personnel to monitor after the computer has announced an event (post-image analysis) will support improved vigilance and increase the probability of incident detection

Southwest Research Institute (SwRI) has developed unique capabilities to provide heightened security and surveillance for a variety of applications. The cornerstone of this capability is our expertise and experience in real-time image processing and machine perception. Video surveillance can provide automatic detection of people and vehicles in video feeds from multiple CCTV (closed circuit TV) cameras. The automated system alerts security personnel and provides data unavailable from conventional systems, such as instant replay. Facilities adopting this technology can significantly increase security because of the untiring vigilance of computer automated video surveillance.

### **The challenge of video security**

Automatic detection and tracking of people in an indoor scene using thermal infrared camera - Commercially available video motion detection systems implement simplistic approaches to incident detection. False triggers are generated by moving foliage, passing headlights, cloud shadows, and more. Operation of these systems is only feasible in highly constrained applications

### **Video security solution**

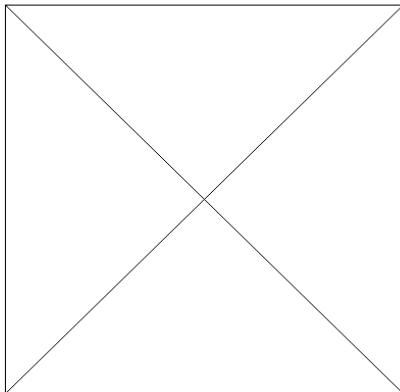

Automatic detection and tracking of people in indoor scene using thermal infrared camera.

Our approach allows moving objects such as animals, people, and vehicles to be recognized, while disregarding and overcoming false triggers caused by moving foliage and changing illumination. In addition, stationary objects added to a scene, such as a package or suitcase, can be detected. This solution is possible because the SwRI advanced algorithms incorporate temporal processing and model-based analysis to achieve machine perception and recognition of normal scene motions. Subsequent discrepancies between the scene and the model can be detected and compared to classification criteria for disposition.

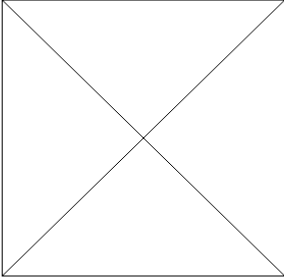

Border Patrol Remote Surveillance Video

Automatic detection of illegal immigrants at U.S.-Mexico border near Eagle Pass, Texas, by computer image analysis of video feed from U.S. Border Patrol remote surveillance unit.

**Interior security** - Hallways, corridors, rooms, courtyards, parking areas, and other interior/exterior spaces can be monitored. Surveillance cameras can be multiplexed for display only when monitored zones are occupied. Detection of specific incidents can be displayed with an associated alarm. Parking lot surveillance could automatically detect persons potentially looking for theft opportunities.

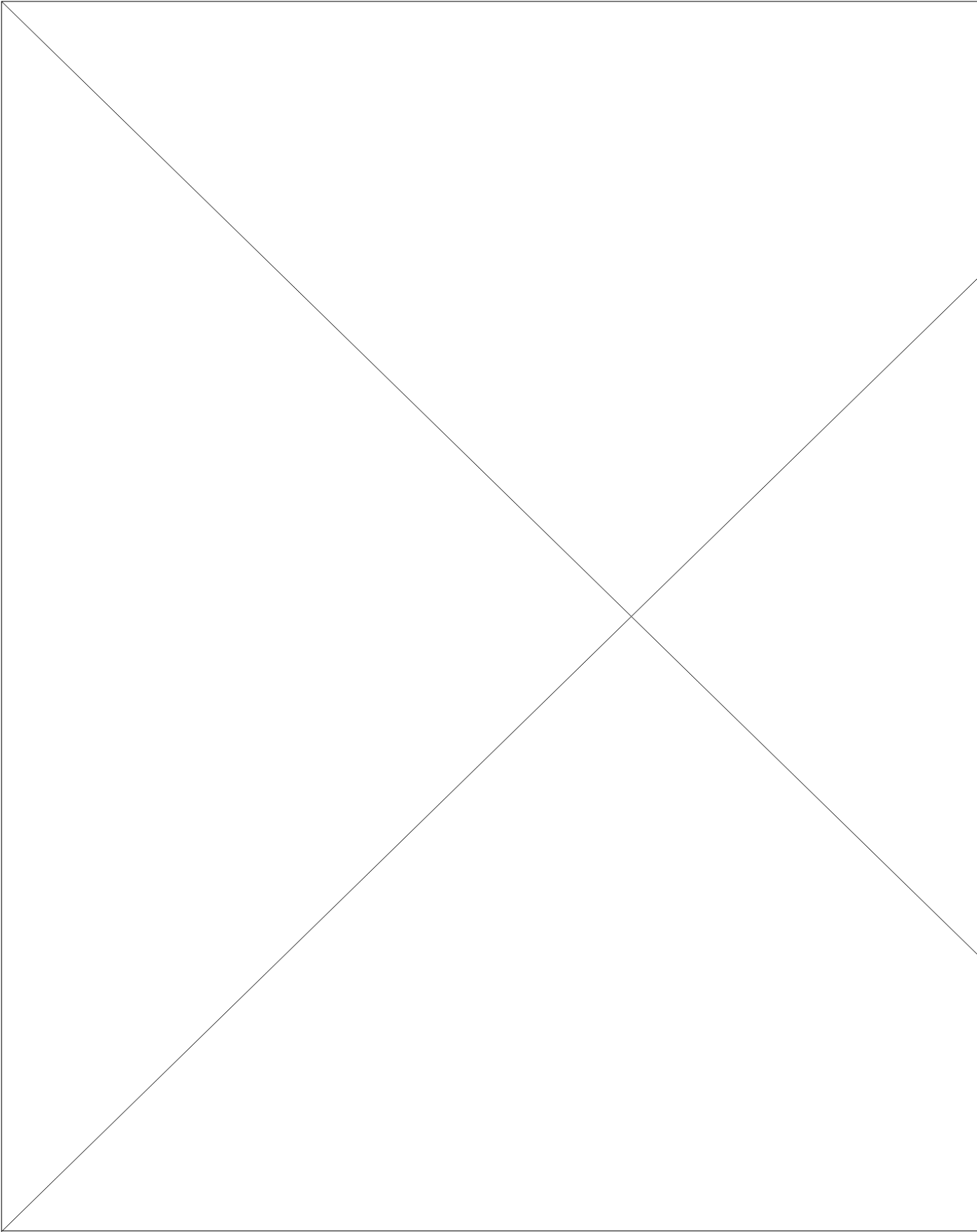



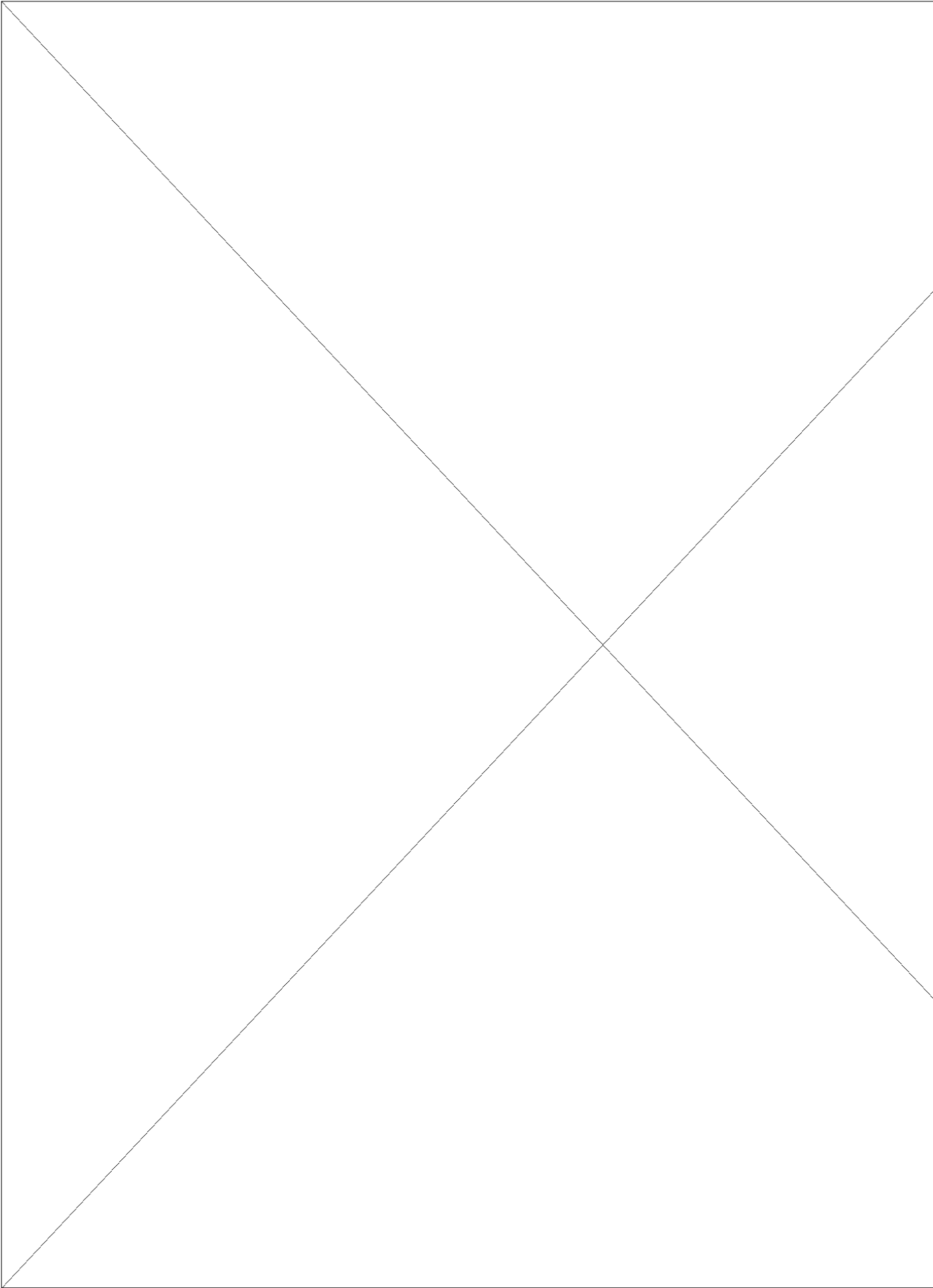

Alarm used for surveillance camera

**Under-Vehicle Surveillance** - Images of vehicle undercarriages can be analyzed to automatically detect attached packages, which could be explosive devices or other contraband.

Example of automated under-vehicle surveillance. (Top) Image of vehicle stored in database. (Middle) Image of same vehicle acquired at a later time (note increased length, subtle brightness differences, and attached package). (Bottom) Resulting image difference and object detection after registering and normalizing the top and middle images.

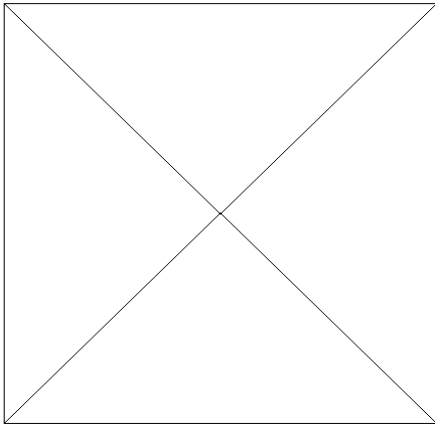

**Safety** - The presence of large animals or joggers can be automatically detected with appropriate warnings provided to motorists.

**Data Acquisition** - Pedestrian or vehicle traffic patterns can be monitored, quantified, and logged. Spatio-temporal analysis can aid in optimization of facility configuration or retail store layout. SwRI software was used to identify and count bees for DARPA-sponsored explosives detection research.

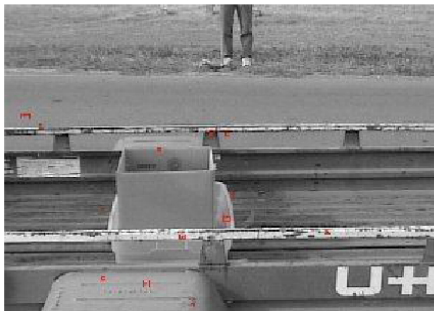

Video of Bees Detecting Explosives

Surveillance software provides automatic detection and counting of bees for DARPA- funded explosives detection research.

### **Video Surveillance System Components**

It may be possible to use existing CCTV surveillance infrastructure; basic system components include cameras, a computer, and Automated Video Security Software. Video feeds are processed by automated surveillance software configured for the specific application. Event detection is brought to the attention of security personnel, and the associated video feed is displayed along with other pertinent information.

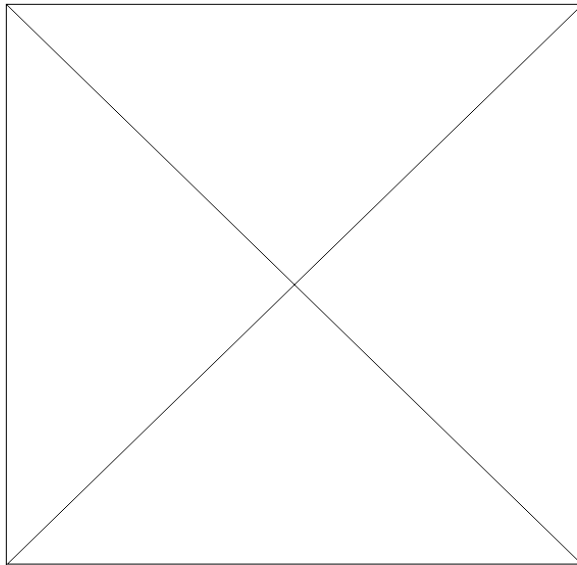

Video surveillance system components

Automated video surveillance system composed of cameras, computers, automated video security software, and video monitors. Systems may incorporate existing surveillance infrastructure. Enhanced capabilities can be provided by a number of optional components

- **Pan/tilt/zoom cameras** operated by computer control.
- **Thermal infrared cameras** for night vision and adverse weather capability (rain/fog/smoke).
- **Visible or near-infrared illuminators** for night vision with conventional cameras.
- **Image intensifiers** for long-range night vision with conventional cameras.
- **Long-range infrared/visible wavelength optics** for perimeter surveillance of large facilities.
- **Remote monitoring** for local computer video analysis with alarm and video data transmitted to remote security personnel upon incident detection.
- **Wireless transmission** so alarms and video data can be transmitted from remote sites via wireless communications media.
- **Mobile platform** so autonomous land or aerial vehicles can carry a surveillance camera and optionally, the analysis computer.

### **ADVANTAGES AND APPLICATIONS**

- ❖ Internet based remote camera control system for remote areas using PC.
- ❖ Home security camera system, security camera system: PC based security provides security camera system equipment to make covert video security which allows you to take advantage of your existing PC to record security video.
- ❖ Video surveillance system designed for homes and small business that manages your video digitally from the camera to the PC.
- ❖ The main advantages of a security system based on commodity components provides a network of analogue or IP cameras and PC-based monitoring application
- ❖ NAVTEX broadcast system control of a PC based surveillance camera control system with secure ports of high-resolution surveillance camera, controlled accesses, and scanners.
- ❖ PC-based surveillance camera control system provides multitasking with access control

- ❖ We are seeing more smart cards now, with their added advantage of providing door controllers, video cameras and security sensors along with PC-based surveillance camera control system.
- ❖ Unfortunately, like most peripherals, PC-based video and web cameras need a web-cam system.
- ❖ Aircraft identification integrated into an airport surface surveillance video system.

### **Scope And Future Trends**

Micro controller is operating at higher frequency, which is sufficient real time environment. PC based surveillance camera is controlled by stepper motor which is operated using COM-1 port of hyper terminal of PC. It can be used in robotics with slight modifications for identifying images using digital image processing. It is basically designed for making compact, flexible, high speed and low power security camera control applications. The open architecture of the system also supports the integration of new analysis making upgrades in expensive and straight forward.

With some other extended software, hardware (such as encoder, decoder and RF module, etc.) it will have lot of scope in

1. agricultural field
2. thermal image processing
3. night vision control system
4. robot cameras
5. Aircraft police or military surveillance camera control system.

for all the above applications it require a auto focus, some closed loop zoom control, auto Irish control, stability of camera platform by gyroscope etc

### **Conclusion**

PC based surveillance system consist of microcontroller, max232, L293D driver, regulated power supply and stepper motor.

The microcontroller operates at 11.05MHz and at a baud rate of 9.6k. The AT89c51 is used because of a low-power; High-performance CMOS 8-bit microcomputer with 4K bytes of flash programmable and erasable read only memory (PEROM).

The MAX232 is a dual driver/receiver that includes capacitive voltage generator to supply voltage levels from a single 5-V supply. The max232 is used to provide serial communication for microcontroller.

The stepper motor is driven with the help of driver i.e.L293D as the controller can't drive a stepper motor which requires above 5v. The status of stepper motor can be changed by com 1 port of hyper terminal. The stepper motor rotates in all direction i.e. clockwise and anticlockwise so that the camera can capture the images in all direction. The programming is done in C-language to the microcontroller using keil software.

The stepper motor is working properly with the given 5V exiting pulses and rotating with step angle for each pulse, which is enough for proper control. Thus the microcontroller is given enable and direction signals to the stepper motor according to the requirement.

The components are assembled and the functionality of each hardware module is checked and the results are satisfactory.

Thus the pc based system for surveillance camera control assembly is successfully designed.